

## WSTQ5080AN

Smart High-Side Power Switch Quad Channel, 80mΩ, DFN9×6-14L , AEC-Q100 qualified

### Application

- ◆ Suitable for resistive, inductive and capacitive loads
- ◆ Replaces electromechanical relays, fuses and discrete circuits
- ◆ Most suitable for loads with high inrush current, such as lamps
- ◆ Suitable for 24 V and 48 V trucks + trailer and transportation systems

### Features

- ◆ PRO-SIL™ ISO 26262-ready for supporting the integrator in evaluation of hardware element according to ISO 26262:2018 Clause 8-13
- ◆ Quad channel device
- ◆ Very low stand-by current
- ◆ 3.3 V and 5 V compatible logic inputs
- ◆ Optimized electromagnetic compatibility
- ◆ Very low electromagnetic susceptibility

### Diagnostic Functions

- ◆ Proportional load current sense
- ◆ High current sense precision for wide range currents
- ◆ Off-state open load detection
- ◆ OUT short to VS detection
- ◆ Overload and short to ground latch-off
- ◆ Thermal shutdown latch-off
- ◆ Very low current sense leakage

### Protection Functions

- ◆ Undervoltage shutdown
- ◆ Overvoltage clamp
- ◆ Load current limitation
- ◆ Self limiting of fast thermal transients
- ◆ Protection against loss of ground and loss of VS
- ◆ Thermal shutdown

### Product Summary

Parameter	Symbol	Value
Max. transient supply voltage( $T_j \geq 25^\circ\text{C}$ )	$V_s$	70V
Operating voltage range	$V_{\text{NOM}}$	5-58V
On-state resistance (per channel, $T_j = 25^\circ\text{C}$ )	$R_{\text{ON}}$	80mΩ
Nominal load current (one channel active, $T_j = 25^\circ\text{C}$ )	$I_{\text{L(NOM)1}}$	2.5A
Nominal load current (All channels active, $T_j = 25^\circ\text{C}$ )	$I_{\text{L(NOM)2}}$	2A
Typical current sense ratio ( $I_{\text{OUT}}=1\text{A}$ )	K	820
Current limitation	$I_{\text{LIMH}}$	5A
Supply current in sleep	$I_{\text{SLEEP}}$	5μA

Package	DFN9×6-14L
Marking	WSTQ5080AN



### Typical Application Circuit

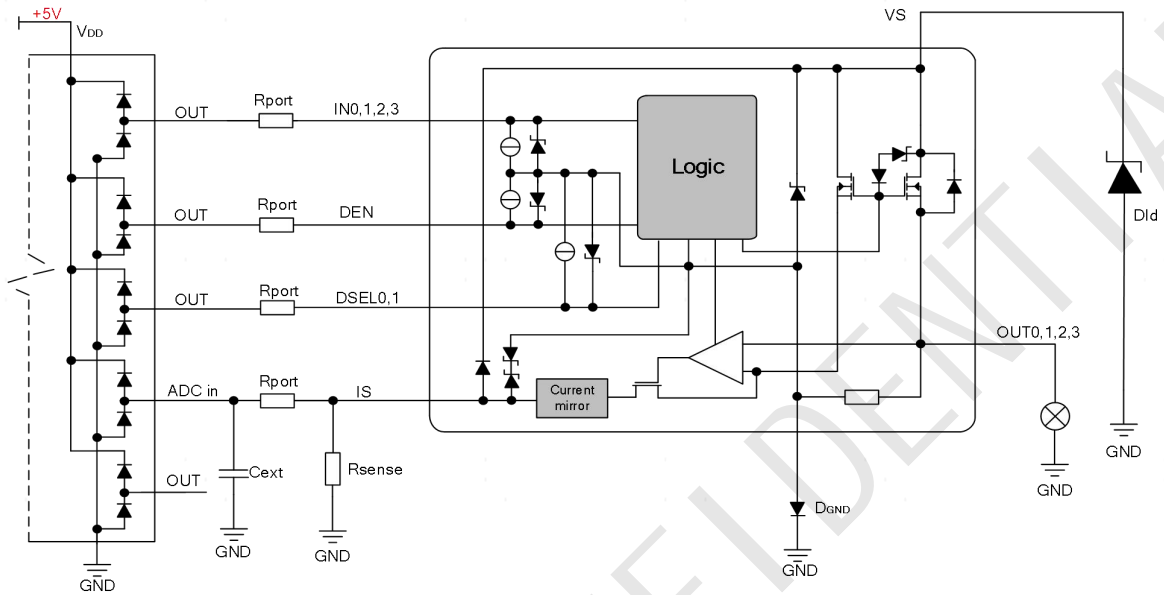

Note1: For D<sub>GND</sub>, the diode with lower V<sub>F</sub> is advisable.